

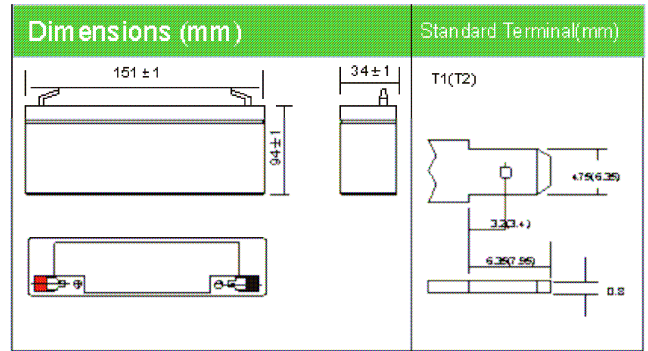

DJW6-7.0(6V7.0AH)

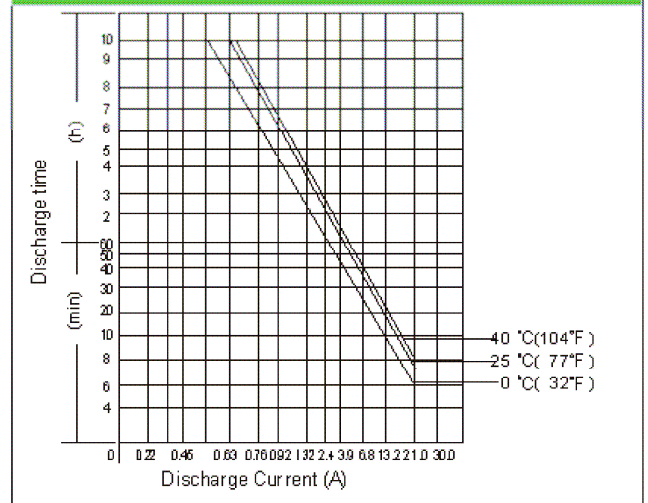

Discharging Current & Discharge Duration Time



Physical Specification

Nominal Voltage		6V
Nominal Capacity (20HR)		7.0AH
Dimension	Length	151 ± 1mm (5.95 inches)
	Width	34 ± 1mm (1.34 inches)
	Container Height	94 ± 1mm (3.70 inches)
	Total Height (with Terminal)	100 ± 1mm (3.94 inches)
Weight		Approx 1.26kg (2.78lbs)
Standard Terminal		T1/T2(standard)

Electrical Specification

Rated Capacity	20 hour rate (350mA)	7.0AH	Constant Voltage	Cycle	Initial Charging Current less than 2.1A. Voltage 7.20V~7.80V at 25°C (77°F) Temp. Coefficient -15mV/°C
	10 hour rate (630mA)	6.3AH			
	5 hour rate (1.19 A)	5.95AH			
	1 hour rate (4.34 A)	4.34AH			
	15minute rate (13.72 A)	3.43AH			
Capacity affected by Temperature	40°C (104°F)	103%	Charge	Standby	No limit on Initial Charging Current Voltage 6.75V~6.90V at 25°C(77°F) Temp. Coefficient- 10mV/°C
	25°C (77°F)	100%			
	0°C (32°F)	88%			

Discharge Characteristics (25°C, 77°F)

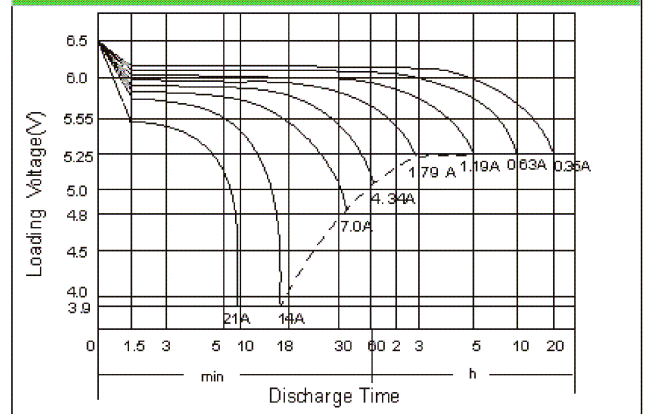

Constant Current (Amp) and Constant Power (Watt) Discharge Table (25°C, 77°F)

Time(minute) Final voltage/C ell	Am p/W att/C ell											
	5	10	15	20	30	45	60	120	180	300	600	1200
A	28.00	19.95	13.72	11.20	8.05	5.60	4.34	2.45	1.79	1.19	0.63	0.35
W	50.12	37.52	26.11	21.91	15.82	11.13	8.61	4.87	3.55	2.38	1.26	0.70