

HIGH RATE SERIES



UPS6-620

**VALVE REGULATED
LEAD ACID BATTERY
FOR UPS STANDBY
POWER APPLICATIONS
6V 200 AH @ 20 HR RATE,
6V 620 WATTS/CELL
@ 15 MIN. RATE**

FEATURES

- Flame-arresting one-way pressure-relief vent for safety and long life.
- Thermally welded case-to-cover bond to eliminate leakage.
- Absorbent Glass Mat (AGM) technology for efficient gas recombination of up to 99% and freedom from electrolyte maintenance.
- Computer-generated grid design optimized for high power density.
- UL-recognized component.
- Multicell design for economy of installation and maintenance.
- Can be mounted in any orientation.
- Not restricted for air transport – Complies with IATA/ICAO Special Provision A67
- Not restricted for surface transport – Classified as non-hazardous material as related to DOT-CFR Title 49 parts 171-189.
- Computer designed lead, low calcium alloy grid for minimal gassing and ease of recycling.
- Case and cover available in both standard and flame retardant polypropylene.
- Flame retardant polypropylene case and cover compliant with UL 1778 (optional).

6 Volts – 620 Watts Per Cell For 15 Minutes to 1.67 Volts per Cell

Constant Power Discharge Ratings – Watts Per Cell @ 77°F (25°C)

End Point Volts/Cell	Operating Time to End Point Voltage (in minutes)									
	5	10	15	20	30	40	45	50	60	90
1.67	940	750	620	525	410	333	309	285	245	173

C&D Technologies, Inc.
DYNASTY Division
900 East Keefe Avenue
Milwaukee, WI 53212
Phone: 800-396-2789
Fax: 414-961-6506



UPS6-620

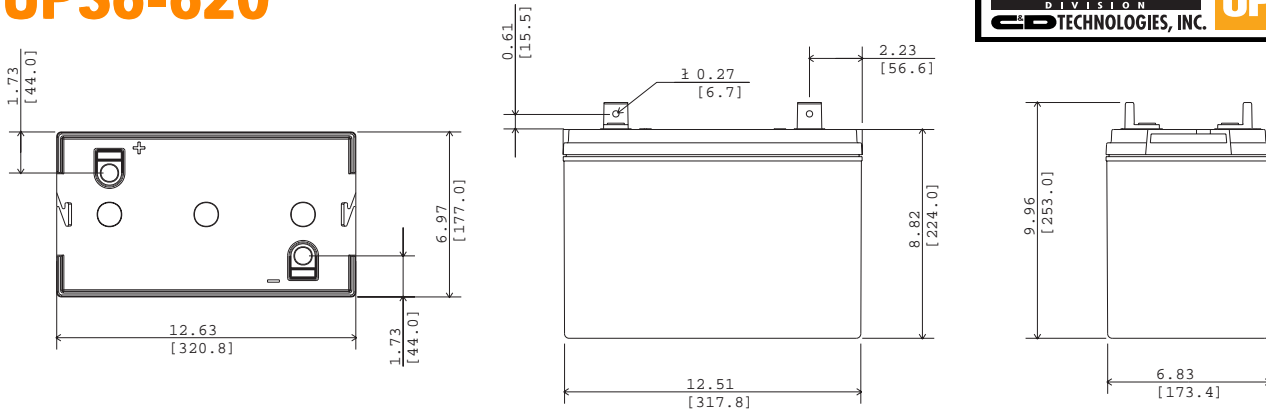

UPS6-620 – Specifications

*All dimensions in inches and (millimeters). All dimensions are for reference only. Contact a C&D Representative for complete dimensional information.

Cells Per Unit	Voltage Per Unit	Weight	Electrolyte	Maximum Discharge Current	Short Circuit Current	Ohms Imped. 60 Hz (Ω)
3	6.42	72 lbs. 33 kg	Absorbed H ₂ SO ₄ SG = 1.300	800 Amps	4350 Amps @ 0.1 sec.	0.0015 Ohms

Capacity	620 watts per cell at the 15 minute rate to 1.67 volts per cell at 77° F (25° C). 200 Ah @ 20 hr. rate to 1.75 volts per cell @ 77° F (25° C) 170 Ah @ 10 hr rate to 1.80 volts per cell @ 20° C (68° F)
Operating Temperature Range	Discharge; -40° F (-40° C) to +160° F (71° C), Charge; -10° F (-23° C) to +140° F (60° C) (with temperature compensation)
Nominal Operating Temperature Range	+74° F (23° C) to +80° F (27° C)
Float Charging Voltage	6.75 to 6.90 VDC/unit Average at 77° F (25° C).
Recommended Maximum Charging Current Limit	C/5 amperes (40 amperes @ 100% depth of discharge) @ 20 hour rate
Equalization and Cycle Service Charging Voltage	7.2 to 7.4 VDC/unit Average at 77° F (25° C).
Maximum AC Ripple (Charger)	0.5% RMS or 1.5% of float charge voltage recommended for best results. Maximum voltage allowed = 1.4% RMS (4% P-P) Maximum current allowed = 9 amperes RMS (C/20)
Self Discharge	Dynasty UPS batteries may be stored for up to 6 months at 77° F (25° C) and then a freshening charge is required. For higher temperatures the time interval will be shorter.
Accessories	Inter unit connectors, racks and cabinet systems are available.
Terminal	"L" terminal with 0.28" clearance hole to accept 0.25" (6mm) bolt.
Terminal Hardware Initial Torque	75 in.-lbs. (8.5 N-m).
Terminal Hardware Annual Retorque	60 in.-lbs. (6.8 N-m)

Constant Power Discharge Ratings – Watts Per Cell @ 77°F (25°C)

Operating Time to End Point (in minutes)

End Point Volts/Cell	5	10	15	20	30	40	45	50	60	90
1.75	840	680	575	500	395	320	297	275	242	168
1.70	890	720	600	520	405	332	306	280	243	170
1.67	940	750	620	525	410	333	309	285	245	173
1.65	950	760	630	532	414	335	311	288	248	176
1.60	1000	790	650	550	420	340	315	290	250	178

Constant Current Discharge Ratings – Amperes @ 77°F (25°C)

Operating Time to End Point Voltage (in hours)

End Point Volts/Cell	.083	.25	.50	.75	1	2	3	5	8	10	12	20	24	72	100
1.90	250	207	149	122	94.0	57.7	42.0	27.9	19.0	15.8	13.5	8.70	7.31	2.51	1.82
1.85	332	248	174	142	110	62.7	45.5	30.0	20.3	16.9	14.5	9.30	7.84	2.73	1.98
1.80	418	288	196	158	120	68.0	48.3	31.6	21.3	17.6	15.2	9.80	8.21	2.83	2.05
1.75	454	312	208	166	123	69.5	50.0	32.4	22.0	18.2	15.6	10.0	8.38	2.87	2.08

Note: Batteries to be mounted with 0.5 in (1.25 cm) spacing minimum and free air ventilation. Specifications subject to change without notification.